



### **i** TECHNICAL SPECIFICATIONS/ORDER SPECIFICATIONS:

<b>Dimensions (Ø x Height):</b>	150 mm x 148 mm	
<b>Housing:</b>	PC/ABS-Blend, grey	
<b>Lens:</b>	PC, transparent	
<b>Fixing:</b>	Base mounting, tube mounting and fixing bracket (accessory)	
<b>Cable entry:</b>	From top or bottom with cable gland M20 x 1.5 mm or from the back with rubber grommet Ø 6-12 mm	
<b>Connection:</b>	Screw terminal, max. 2.5 mm <sup>2</sup>	
<b>Flash frequency:</b>	1 Hz	
<b>Flash energy:</b>	15 Ws	
<b>Life duration:</b>	4 x 10 <sup>6</sup> flashes	

<b>Voltage:</b>	24 V DC	230 V AC
<b>Current consumption:</b>	800 mA	200 mA
red	<b>897 100 55</b>	<b>897 100 68</b>
yellow	<b>897 300 55</b>	<b>897 300 68</b>

Further colours and voltages on request.

### **🏠** ACCESSORIES:

Fixing bracket, adhesive stickers see Permanent/  
Traffic Light Beacon 890 (page 181).

### **📏** TECHNICAL DIAGRAM:

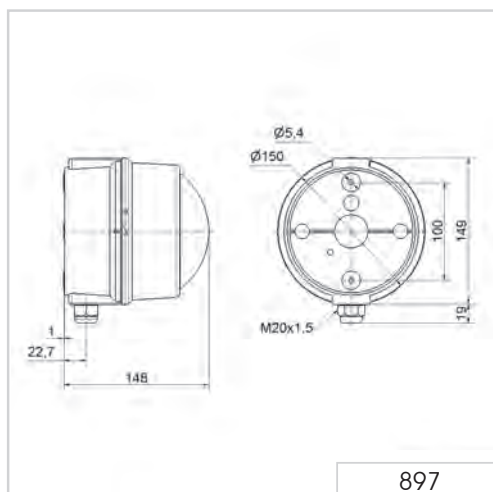

#### Signalisation index

Xenon Flashing Light

