



Modified flashing beacon 828 specifically for use in road tunnels

**i TECHNICAL SPECIFICATIONS/ORDER SPECIFICATIONS:**

Dimensions (Ø x Height):	98 mm x 137 mm
Housing:	PC/ABS-Blend
Lens:	PC, transparent
Fixing:	Base mounting, bracket mounting (accessory)
Cable entry:	Cable diameter 5-7 mm
Connection:	Screw terminal 0.5 - 1.5 mm <sup>2</sup>
Flash energy:	5 Ws
Flash frequency:	C. 1 Hz
Life duration:	4 x 10 <sup>6</sup> flashes
Voltage:	230 V AC
Current consumption:	140 mA
yellow	<b>828 370 68</b>
clear	<b>828 470 68</b>

**ACCESSORIES:**

Plastic bracket for wall mounting	<b>975 826 05</b>
Wire guard, galvanised, only for base mounting	<b>975 826 03</b>

**TECHNICAL DIAGRAM:**

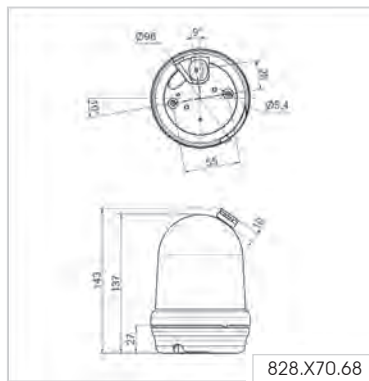

Clear identification of escape routes can save lives



A special valve in the lens also prevents the build-up of condensation inside the beacon

Signalisation index	
Xenon Flashing Light	7

