

Safety-contact-mat STM

Now New !
One-component molding technique
with molded ramp rails !

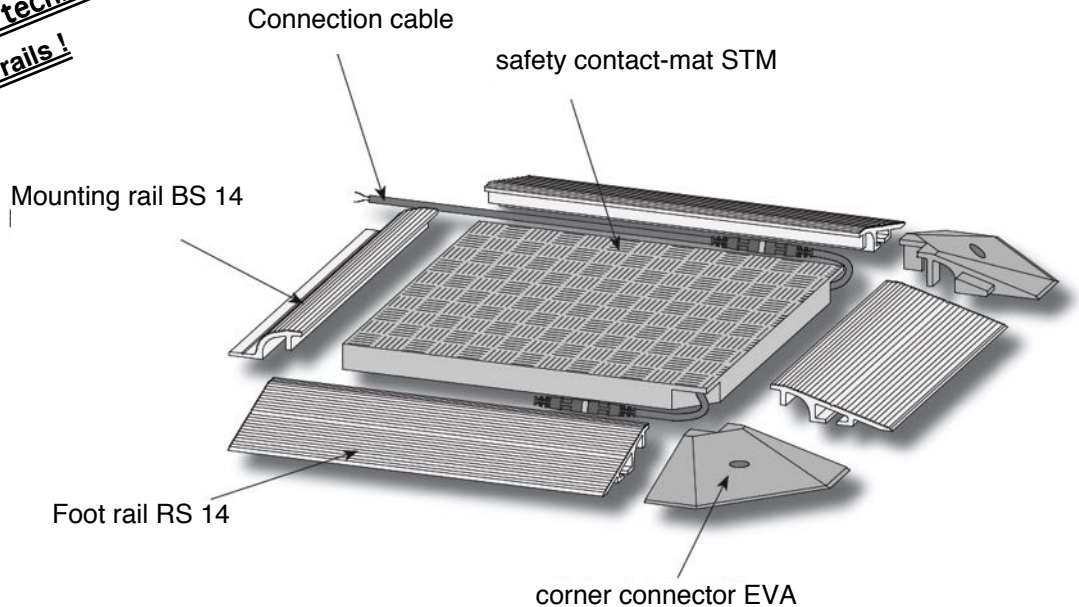

The safety contact-mat STM is used for safeguarding sections in hazardous areas of working for machinery, e.g. presses, robots and other types of swiveling equipment. Walking on the mat triggers a control signal to the immediate- stop device of the potentially hazardous motion.

This quick-action contact-making is made possible by surface-area switch on the inside of the mat that is encased in polyurethane to ensure impermeability to water. A platform made of plastic or metal serves as the carrier. The surface can be protected by adhesion-bonding an anti-slip rubber covering to thereby give high grip to the surface. Checkered surfaces in aluminum or high-grade steel can be used for high mechanical demands placed on the upper mat surface. Special evaluation units monitor the switching function of the reliable safety contact-making mats.

Safety category Type 3 - Performance Level d



High moisture resistance
Easy to clean from dust and dirt



More than 6 million cycles
Single component encapsulation in several colors

Standard dimensions and individual shaping possible



Up to 10 mats in series connectable

Very short response time - Static load up to 2000 N



Polyurethane,- Aluminium- or Stainless steel surfaces available

The principle of the safety-contact-mat :

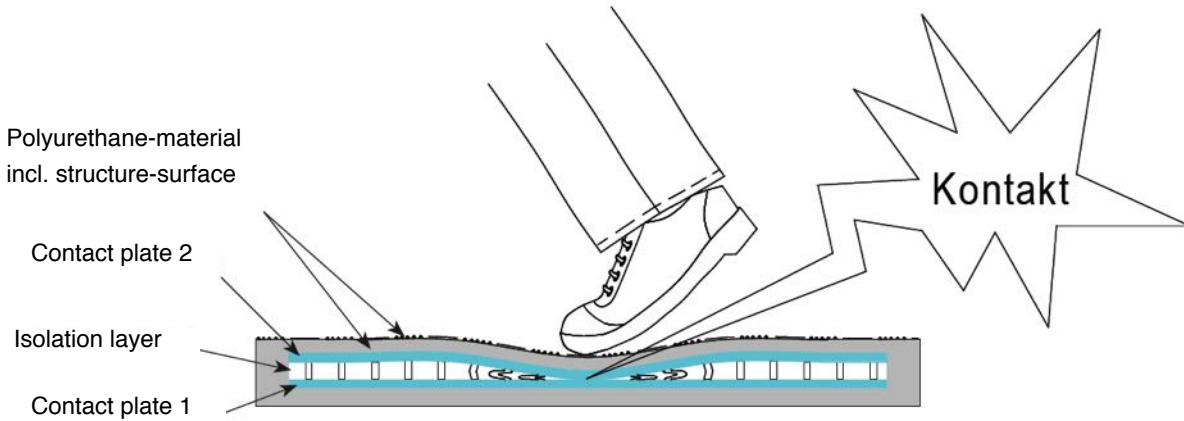

The structure:

The basic construction of the STM Safety Contact Mat consist of two conductive plates which are separated by a proprietary isolating layer. These plates are completely potted in a polyurethane material so that they are impervious to oil, water and dirt. The top consists of a slip resistant checkered pattern. This surface provides excellent resistance against oil and grease. Two cable exits are provided. These cables consist of one M8 male plug and one M8 female plug in standard construction (Optional Cable Exits are available upon request). Mounting to the floor can be realized with optional aluminum ramp rails RS 14 or BS 14.

Please pay attention to:

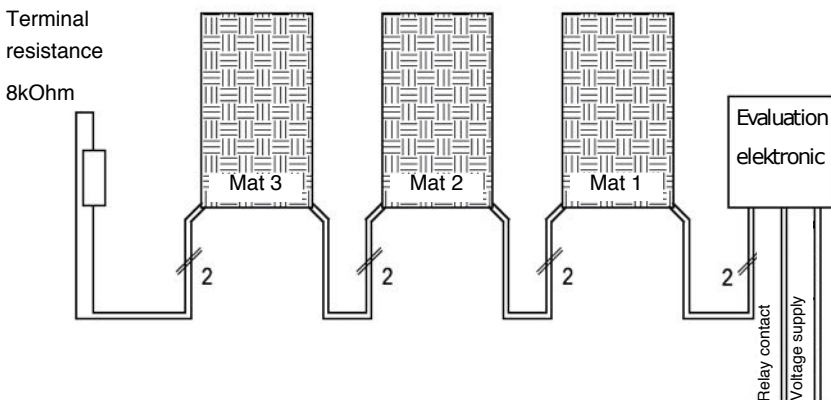

- Up to 10 contact mats wired in series may be connected to one evaluation control unit
- The maximum total area can not exceed 10 m²!
- The total cable length can not exceed 25m
- The 8.2 KΩ terminal resistance must be connected to the last mat in series when several mats are connected !
- Please inquire separately for mats with recesses or special shapes.

Signal processing:

The STM safety contact mat is fitted with 2 two-core connecting cables and offers the possibility of connecting several mats in series up to a maximum total area of 10 m². One end of the cable is connected to the safety evaluation control electronics and the terminal resistance is connected to the other end (prepared at the factory). The Safety Evaluation control electronics provides monitoring for the entire circuit including the cabling route and the mats, by monitoring the terminal resistance. The two surfaces of the mat make contact when stepped on and the resistance is bridged. This immediately causes a signal within the electronics that is then given as a potential free output for the contact-mat by the relay. The entire switching circuit is monitored at the same time for damage to cable or manipulation.

Ramp rail RS 14:

The ramp rail RS 14 provides secure mounting capability for the safety contact mat. The angled design reduces tripping and slipping when mounted to the mat. The integrated channel can be used for clean and safe installation of the connecting cable.

Mounting rail BS 14:

The mounting rail BS 14 can be used to attach the safety contact mat in less accessible areas (for example at machines, shut-off positions, walls, etc.).

Also the integrated channel can be used for clean and safe installation of the connecting cable.

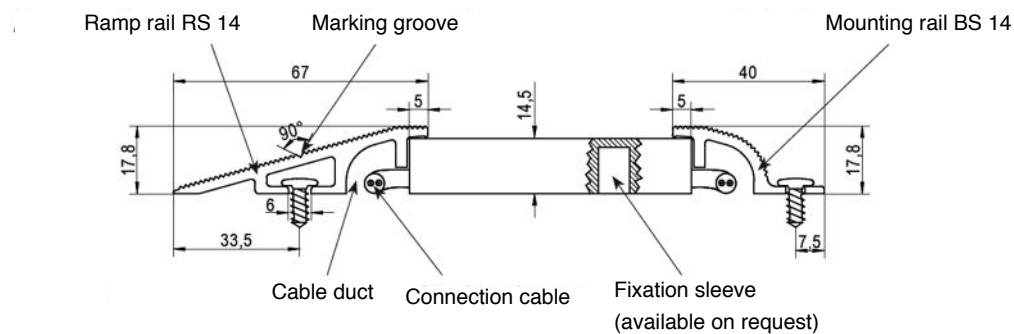

Molded ramp:

Firmly padded with the mat.

Mat can be screwed directly through the cast-on ramp rail.

Orientation groove to fix the screws provided.

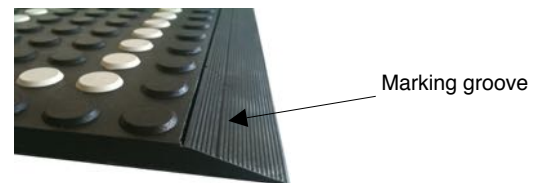

Fixation sleeve:

This enables the safety contact mat to be fixed to the floor without additional space being needed.

Covers :

NP - Euro dot surface with one compound mat

AL - One compound mat with aluminium plate

V2A - One compound mat with stainless steel plate

Mats connection with M8 coupling and plug:

Cable outputs

optional

Customer request

possible!

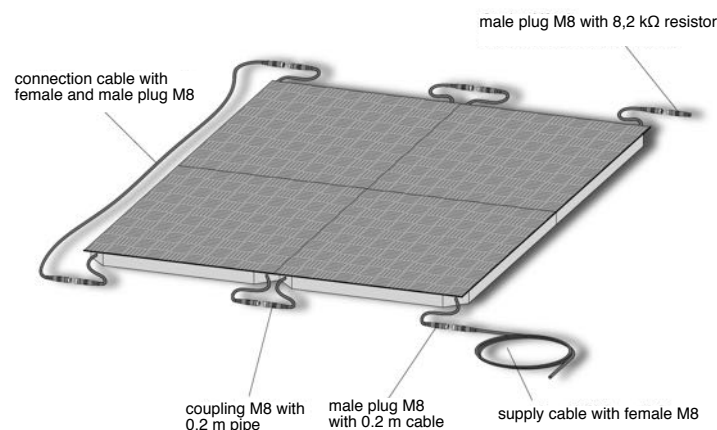

Technical specifications for Safety contact mats :

Max. dimension:	2350 mm x 1350 mm
<u>EN ISO 13849-1</u> <u>(with STM STK 41-322)</u>	EN ISO 13849-1 Cat. 3 PLd (MTTFd 329 Years, DC 97%) (adopted 52.560 cycles)
Construction height :	14 mm with surface
Weight :	ca. 25 kg/m ²
Inactive border :	max. 10 mm circulating
Switching pressure :	Round body Ø 80 mm = approximately 150 N
Static load :	maximum 2000 N - Ø 80 mm *
Response time :	maximum 25 ms *
Switching cycles :	at least 10 Mio. (B10d : 2.000.000) *
Electrical capacity :	24 V 100 mA
Material :	Polyurethane black
Protection class :	IP 65
Temperature range :	0 °C to + 60 °C
Chem. resistance:	Oils, greases - good, 10% acids - resistant, 10% alkalis - resistant

* tested according to EN 1760-1

Maintenance: The mat is maintenance-free.

An annual function test is recommended.

Connection cable: standard: pluggable, 2 x 0,34 PU-jacket black with M8 connector design, 120mm long

Technical specifications foot/ramp rail RS 14:

Material: aluminum AlMgSi 0,5
Standard delivery lengths: 2 m / 6m
Weight: approx. 788 g/lfm

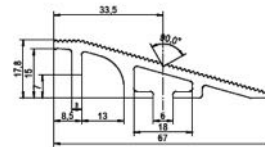

Technical specifications mounting rail BS 14:

Material: aluminum AlMgSi 0,5
Standard delivery lengths: 2 m / 6m
Weight: approx. 408 g/lfm

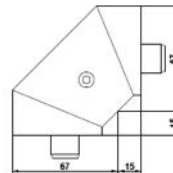
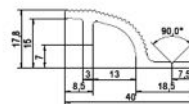

Technical specifications corner connector EVA:

Material: PA 6 black

Technical specifications of the tread:

Typ:	AL	V2A	RF / NP
Material	Aluminum AlMg3	Stainless steel	Polyurethane black
Kind	Riffelblech	Tear plate	Euro dot surface
Color			black
Thickness	max. 4,5 mm	max. 4,5 mm	14 mm
Delivery widths	max. 1,5 m	max. 1,5 m	max. 1,35 m
Delivery lengths	max. 3,0 m	max. 3,0 m	max. 2,35 m
weight	ca. 7,0 kg/m ²	ca. 11,6 kg/m ²	ca. 15 kg/m ²
Chem. Resistance			
Oil	good	very good	good
Petrol	good	very good	resistant
Solvent	good	very good	sufficient
Acids	good	very good	resistant
Alkaline solutions	good	very good	resistant

Assembly Information:

The mounting surface must be absolutely even, clean and dry. All cables must be laid protected against damage (squeezing, shearing, etc.).

Mats must not be glued. Place the safety step mat on the floor and position it correctly. Mats must not be bent or bent. Safety- Contact-Mats may not be changed in any way. Cut outs or shortening is not possible.

When installing several mats next to each other they are put together edge to edge. Then connect the mats electrically and check the resistance value.

With not activated mat the value must be $8,2 \text{ k}\Omega \pm 500 \Omega$.

During cable laying inside the ramp- and/or in the mounting rail pay attention that the cable is not pinched.

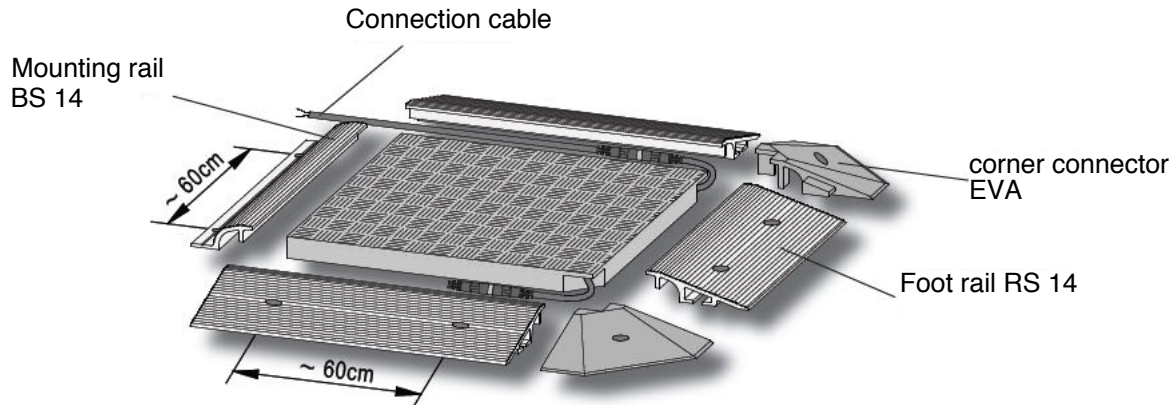
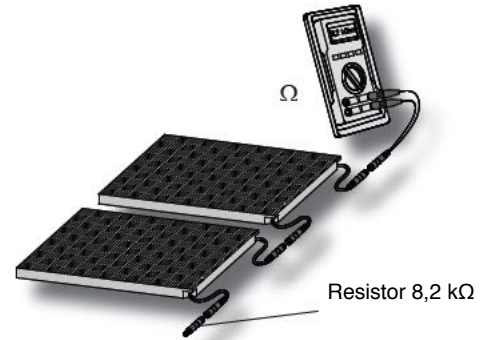

Assembly:

When using corner connectors the ramp rail must be shortened around 20mm for each corner connector.

The corner connector nearest the cable is to be mounted from above over the cable in such a way that the cable is guided safely in the cable duct (fig. 1). Afterwards drill and fasten it to the bottom with 6 mm dowel and suitable screw.

Push the ramp rails laterally to the mat and then on the fixation-pin of the corner connector (fig. 2). Mark the fastening points along the marking groove on the rail and pre-drill 10 mm for the intended plugs. Fasten the rails on the bottom with 6 mmdowels and suitable screws (approx. all 60 cm) and close the openings with the plugs (fig. 3).

Push the corner connectors laterally to the mat and then the fixation-pin into the rail (fig. 4). Afterwards drill and fasten it to the bottom with 6 mm dowel and suitable screw.

At the machine side the conclusion takes place via the adjustment with the mounting rail BS 14. Fasten the rail to the bottom with 6 mm dowels and suitable screws (approx. all 60 cm). If possible bring out the cable laterally and attach it to the controller (fig. 5).

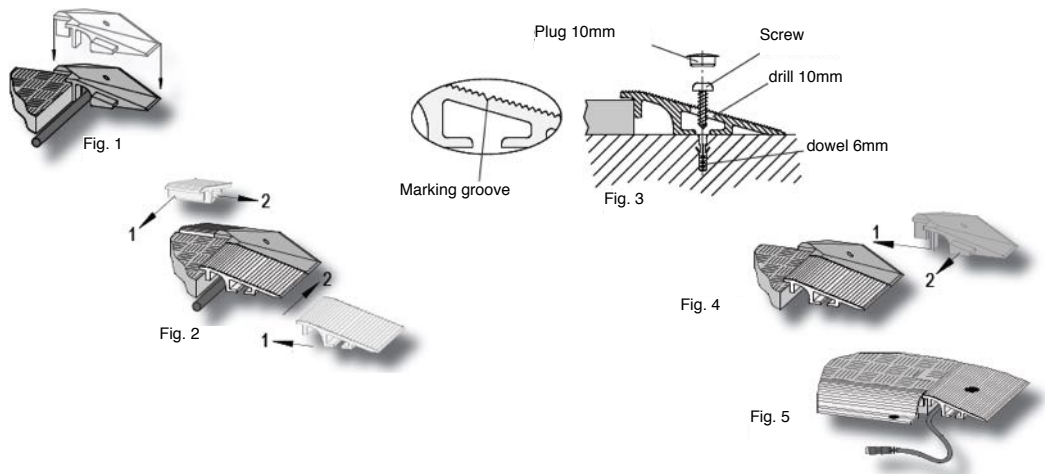

Special installation instructions for the installation of the metallic corrugated coverings made of aluminum and stainless steel:

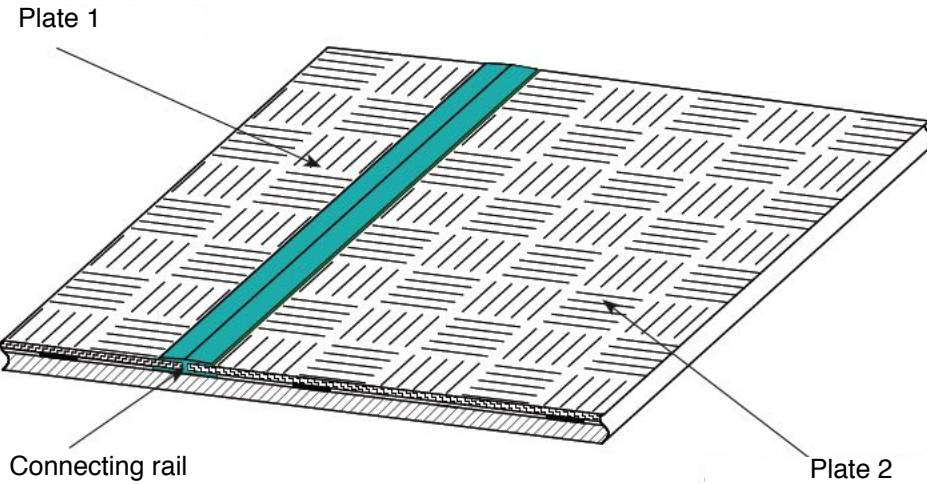

Mounting mats with metallic plates of aluminum (ARB) or stainless steel (TBV), make sure that the plates are only placed and fixed by the surrounding rails. The plates must not be stuck! Multiple metal plates must be connected by connecting rails.

Please note for measurement:

The area to be protected is the measure of the safety mat.

For this purpose, the dimensions of 62 mm (for the ramp rail RS 14) and 35 mm (for the mounting rail BS 14) must be added. This gives the entire space requirement. The mounting rail and the ramp rail are required to fix the mat to the floor.

The maximum achievable size of a mat is 2350 mm x 1350 mm. Above-ground dimensions can be realized by linking individual mats.

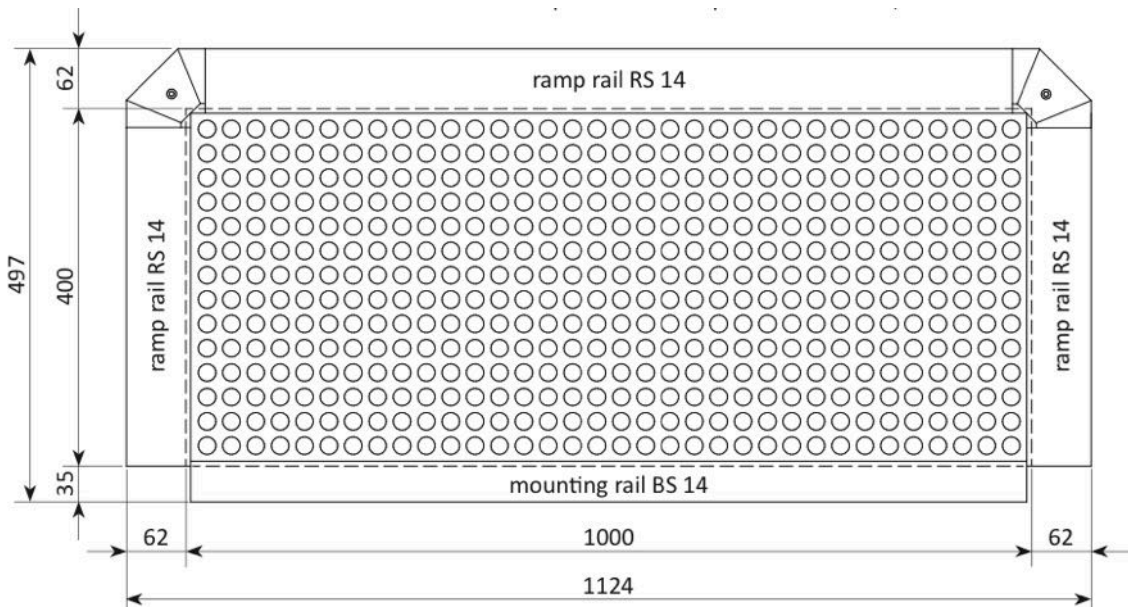

Assembly of mats with molded ramp rails:

Please note for dimensioning:

The area to be safeguarded is the dimensions of the mat without the ramp rails. Therefore 35mm have to be added for each ramp rail side. The result is the over-all dimension for the floor space.

The ramp rail serves for fixation to the ground.

250 cm x 140 cm is the maximum producible size of a mat. All dimensions larger than this have to be realized by using several mats.

Installation:

Cut out the cable output at appropriate side in that way that the coming out cables are not squeezed or sheared while placing the mat afterwards. Place and adjust the mat at appropriate place. To provide against slipping use suitable screws and dowels on each side of the mat.

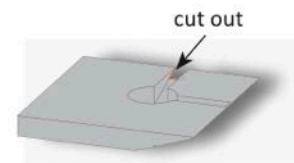
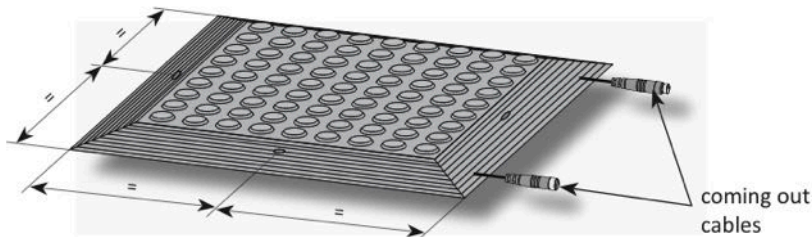
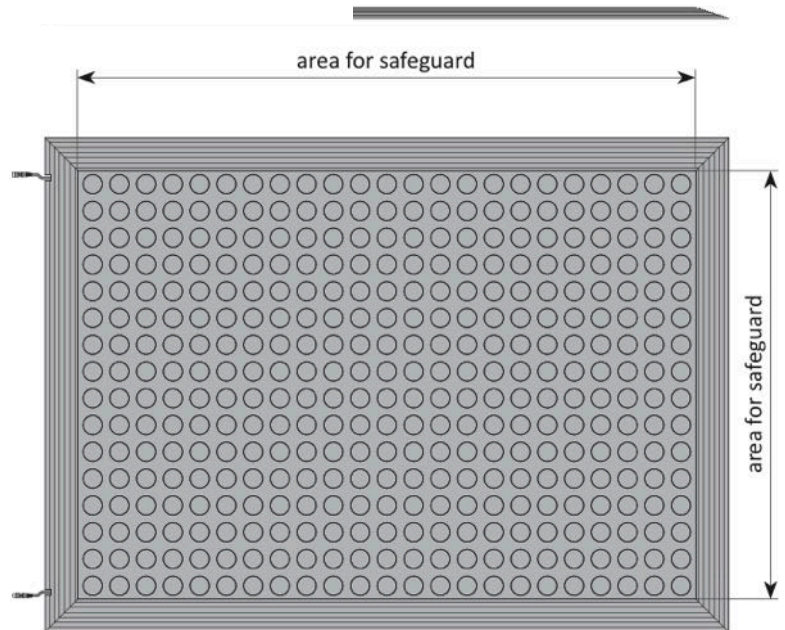

When installing several mats next to each other they are put together edge to edge. To do this cut off the ramp rail with a knife in the given slit (spray the knife and the cutting area with soapy water).

Adjust the mats and save each against getting out of place.

After that connect the mats electrically and check the resistance value. With not activated mat the value must be $8,2 \text{ k}\Omega \pm 500 \Omega$.

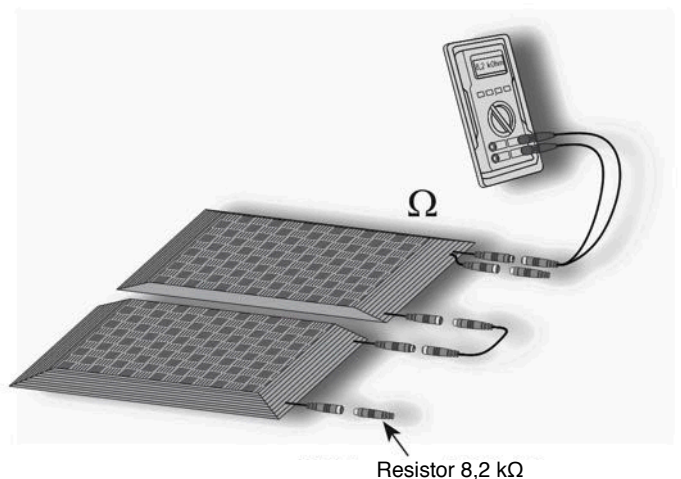
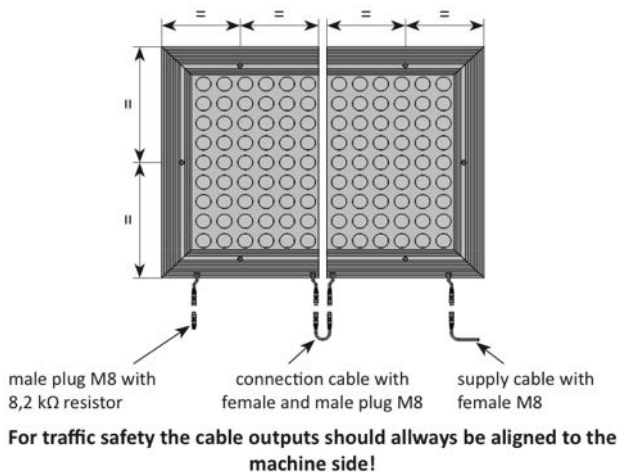

Calculation safety distance:

According to the standards EN ISO 13855 and EN 1760-1 floor mounted protection devices, thus also safety contact mats, must be calculated according to the following formula:

$$S = (1600 \text{ mm/s} \times T) + (1200 \text{ mm} - 0,4 \times H)$$

where:

S the minimum distance (minimum size of the mat) in millimeters, measured on a horizontal level between the hazard motion and the active edge of the protection device (safety mat) furthest from the hazardous point of the machine.

T response-time of the overall system $T = t_1 + t_2$

t₁ the maximum time between the actuation of the safety mat and the controller output relays being in the de-energized state.

t₂ the response time of the machine being guarded. The time required to stop the machine or remove the risk receiving the output signal from the mat system.

H the distance above the reference plane (floor) in millimeters when mats are mounted on the floor $H=0$

Example:

Supposed the maximum response time of the guarded machine is 200ms and the response time of the safety mat with the SK 41-32 safety controller is 15ms. The Safety-mat will be mounted at the reference plane (floor) ($H=0$).

$$S = (1600 \text{ mm/s} \times T) + (1200 \text{ mm} - 0,4 \times H)$$

$$S = (1600 \text{ mm/s} \times (0,2 \text{ s} + 0,015 \text{ s})) + (1200 \text{ mm} - 0,4 \times 0 \text{ mm})$$

$$S = (1600 \text{ mm/s} \times 0,215 \text{ s}) + (1200 \text{ mm} - 0 \text{ mm})$$

$$S = 344 \text{ mm} + 1200 \text{ mm}$$

$$S = 1544 \text{ mm}$$

This calculation specifies that the distance between the active edge of the protection device and the hazardous point of the machine should be at least 1544mm. This floor area can be guarded by a safety mat to prevent any undetected access to the hazardous point of the machine.

This formula assumes that the person approaching the dangerous area is at walking speed.

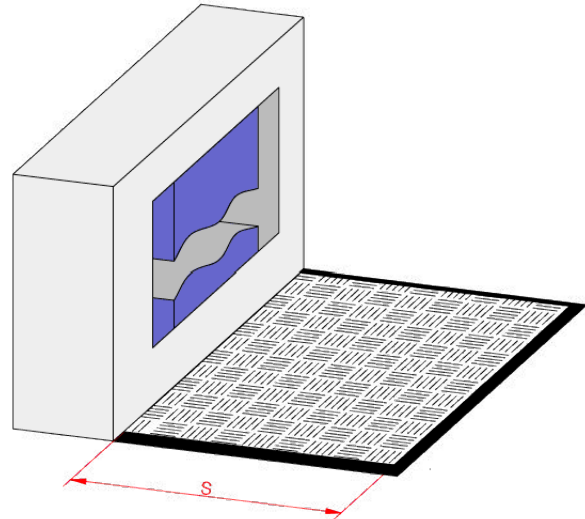

Safety contact mat in hazardous (explosion) areas

description of the Zener Barrier:

If a safety contact mat is to be used in a hazardous area, a Zener barrier must be used. The Zener Barrier is an electrical device used as a safety barrier in explosion protection. Their task is to prevent the ignitability of circuits that are placed in an explosive atmosphere and to prevent the penetration of ignitable energy, voltage or current into an explosive atmosphere.

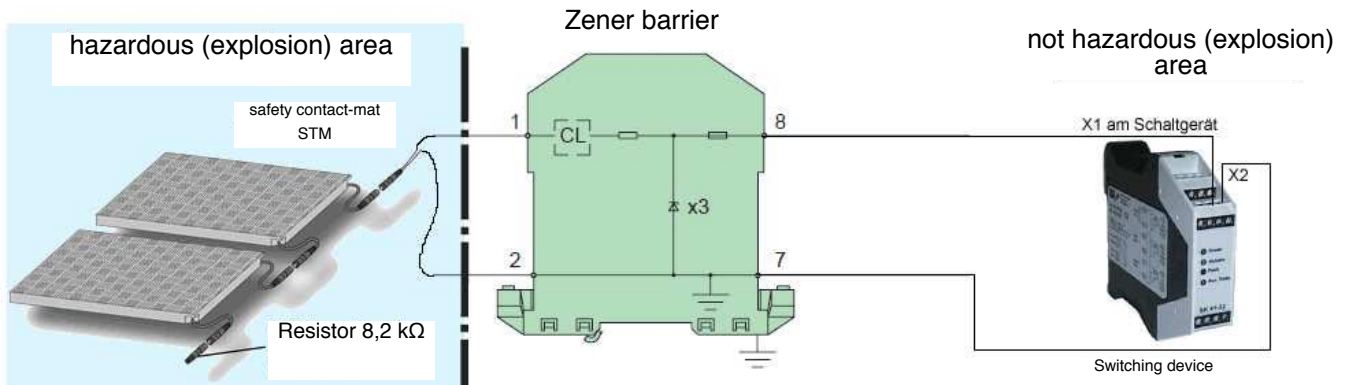

M8 coupling connector:

Connector (male) M8

coupling (female) M8

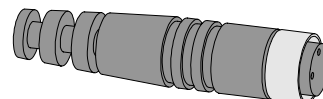
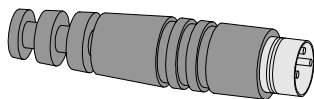
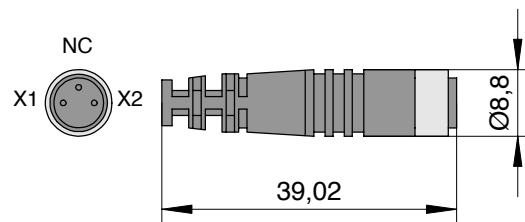
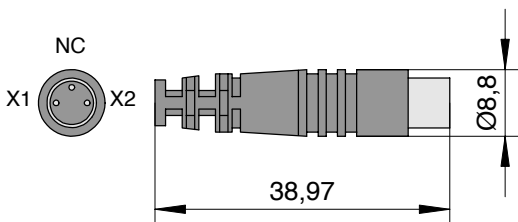

Notes:

Delivery program

Fiessler Elektronik
 Kastellstr. 9 D-73734 Esslingen
 Telefon: 0711 / 91 96 97-0
 Telefax: 0711 / 91 96 97-50
 WWW.fiessler.de
 E-Mail: info@fiessler.de

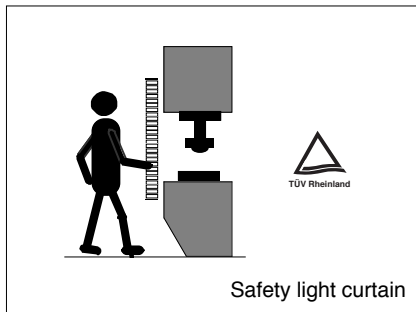

Safety light curtain

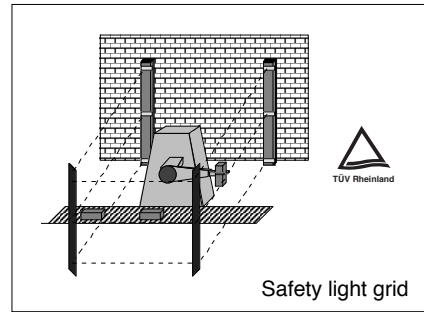

Safety light grid

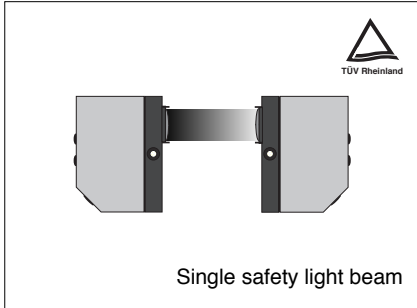

Single safety light beam

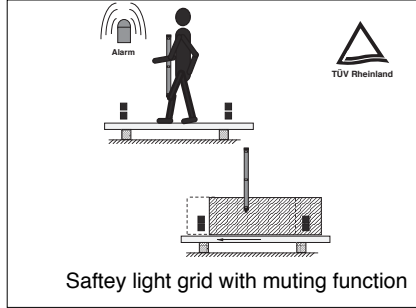

Safety light grid with muting function

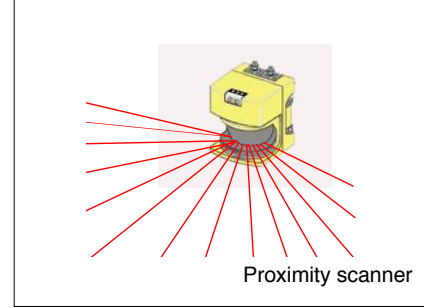

Proximity scanner

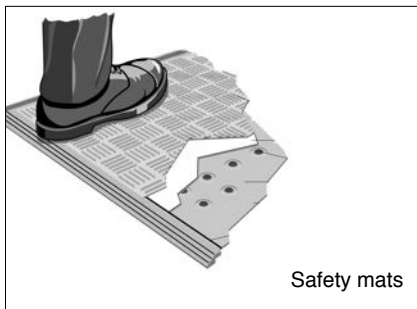

Safety mats

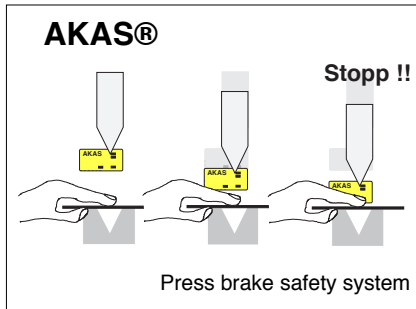

Press brake safety system

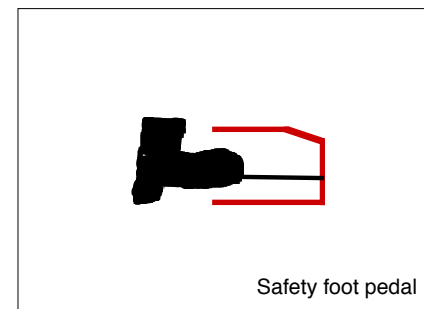

Safety foot pedal

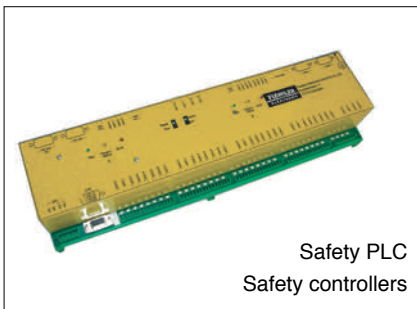

Safety PLC
 Safety controllers

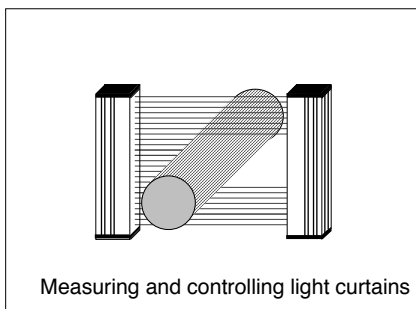

Measuring and controlling light curtains

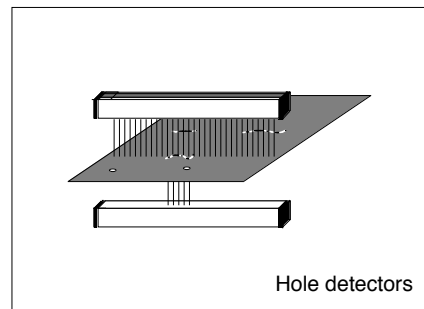

Hole detectors

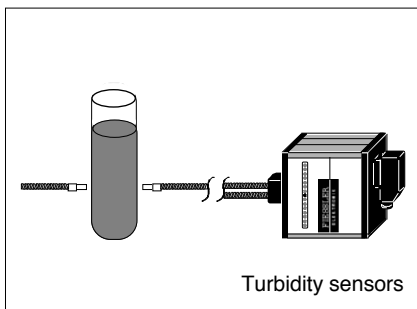

Turbidity sensors

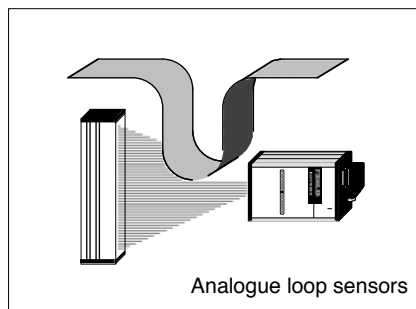

Analogue loop sensors

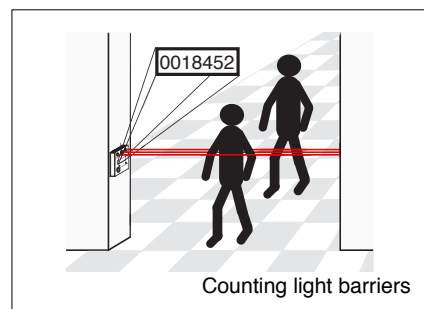

Counting light barriers

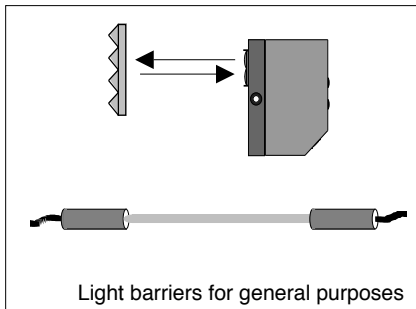
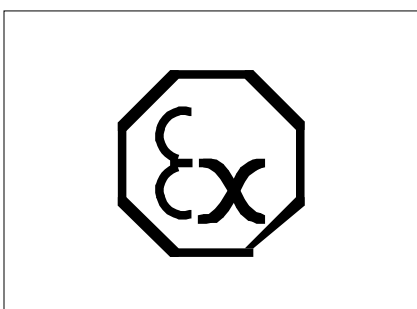

Light barriers for general purposes



Your application