



Obstruction Light



Why do obstacles need to be illuminated?

The law stipulates that buildings of a specific height and in the vicinity of airports as well as factory chimneys, towers, masts etc. must be equipped with obstruction lights.

This special lighting makes obstacles visible for pilots in the dark or when visibility is poor. Obstruction lighting is one of the most important aspects of flight safety.

What directives and regulations are there?

The method of marking obstacles to air traffic is laid down by diverse laws, regulations and recommendations. These regulations have a clearly defined sphere of influence and are **internationally interlinked**.

The International Civil Aviation Organisation (**ICAO**) is a special organisation within the United Nations created to establish and develop universal regulations for safety, continuity and economic efficiency in international air traffic. The recommendations of the ICAO are not directly binding in the member states, but must be transformed by them into the appropriate **national legal regulations**.

In **Germany** the Ministry for Transport and Construction Development (**BMVBS**) issues the regulations covering obstruction lighting on buildings. The **ICAO** regulations regarding the methods of marking and lighting aviation obstacles can be found in ICAO Annex 14.

- **"Low intensity obstacle beacon type A"**: a red permanent night-time warning beacon for fixed obstructions with a brightness of 10 cd.
- **"Low intensity obstacle beacon type B"**: a red permanent night-time warning beacon for fixed obstructions with a brightness of 32 cd.

Where are obstacle lights deployed?



- **Germany**: Marking of aviation obstacles by night at any height providing the highest point of the obstacle can be marked.



- **According to ICAO**: Marking of aviation obstacles by night up to 45 m ("Low-intensity Obstacle Light, Type A"), additionally in combination with "medium-intensity obstacle lights"



280 Low-intensity LED Obstruction Light Type A and B



LED Obstruction Light Type B



LED Obstruction Light Type A - The adaptor (accessory) allows quick and simple mounting on a tube



Plastic bracket, adaptor for tube mounting (accessories)

① TECHNICAL SPECIFICATIONS/ORDER SPECIFICATIONS:

Dimensions (Ø x Height):	142 mm x 218 mm
Housing:	PC/ABS-Blend
Lens:	PC, transparent, clear
Connection:	Screw terminal 0.5 - 1.5 mm ²
Cable entry:	Cable diameter 5-7 mm
Fixing:	Base mounting, bracket mounting (accessory), tube mounting (accessory)
Duty cycle:	100 %
Life duration:	Up to 50,000 hrs
Current consumption at failure of 2 of the 12 LED strips:	< 50mA

Low-intensity LED Obstruction Light Type A

Voltage:	12-50 V DC		
Current consumption:	500-100 mA		
aviation red	280 410 55		

Low-intensity LED Obstruction Light Type B (includes Type A)

Voltage:	24 V DC	230 V AC	230 V AC (with monitoring funct.)
Current consumption:	~ 500 mA	~ 200 mA	~ 200 mA / < 50 mA (Failure mode)
aviation red	280 470 55	280 470 68	280 480 68

✳ ACCESSORIES:

Plastic bracket for wall mounting	975 883 06
Wire guard, only for base mounting	975 883 08
Adaptor for tube mounting	975 883 09

↔ TECHNICAL DIAGRAM:

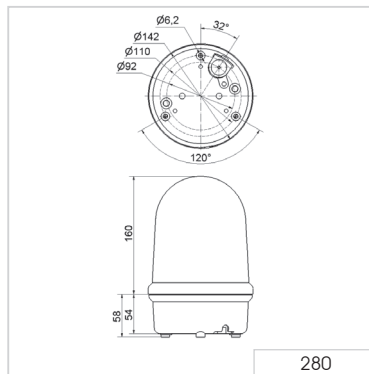



LED Obstruction Light Type B



LED Obstruction Light Type A

281 Low-intensity LED Obstruction Light Type A and B

① TECHNICAL SPECIFICATIONS/ORDER SPECIFICATIONS:

Dimensions (Ø x Height):	165 mm x 205 mm
Housing:	Aluminium, coloured powder coating
Lens:	Reinforced borosilicate glass
Connection:	Screw terminal 0.5 - 1.5 mm ²
Cable entry:	Cable gland M25 x 1.5 mm (included in assembly), Cable diameter 9-17 mm Reducer unit (included in assembly)
Fixing:	Base mounting, tube mounting M25 (no accessory required)
Life duration:	Up to 50,000 hrs

Low-intensity LED Obstruction Light Type A

Voltage:	12-50 V DC		
Current consumption:	500-100 mA		
aviation red	281 410 55		

Low-intensity LED Obstruction Light Type B (includes Type A)

Voltage:	24 V DC	230 V AC	230 V AC (with monitoring funct.)
Current consumption:	~ 500 mA	~ 200 mA	~ 200 mA / < 50 mA (Failure mode)
aviation red	281 470 55	281 470 68	281 480 68

← TECHNICAL DIAGRAM:

