

# 897 Xenon Double Flash Beacon



## ① TECHNICAL SPECIFICATIONS/ORDER SPECIFICATIONS:

Dimensions (Ø x Height):	150 mm x 148 mm	
Housing:	PC/ABS-Blend, grey	
Lens:	PC, transparent	
Fixing:	Base mounting, tube mounting and fixing bracket (accessory)	
Cable entry:	From top or bottom with cable gland M20 x 1.5 mm or from the back with rubber grommet Ø 6-12 mm	
Connection:	Screw terminal, max. 2.5 mm <sup>2</sup>	
Flash frequency:	1 Hz	
Flash energy:	15 Ws	
Life duration:	4 x 10 <sup>6</sup> flashes	
Voltage:	24 V DC	230 V AC
Current consumption:	700 mA	200 mA
red	<b>897 100 55</b>	<b>897 100 68</b>
yellow	<b>897 300 55</b>	<b>897 300 68</b>

Further colours and voltages on request.

## ✂ ACCESSORIES:

Fixing bracket, adhesive stickers see Permanent/Traffic Light Beacon 890 (page 140).

## ↔ TECHNICAL DIAGRAM:

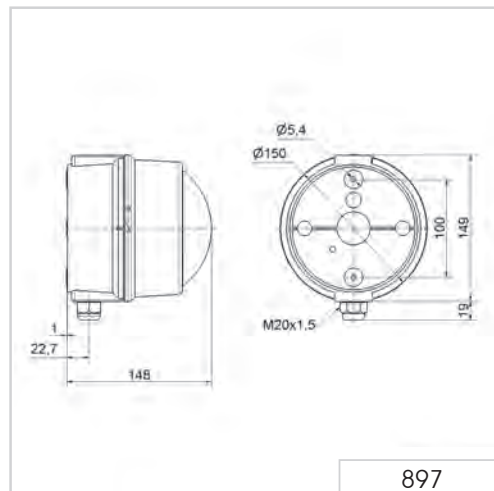

### Signalization index

Xenon Flashing Light

9

